

1. Straighten and assemble all bungeed poles.

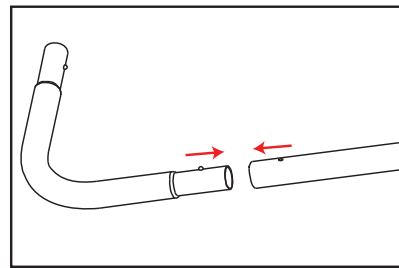

2. Assemble the frame by aligning the stickers as seen in the frame diagram above.

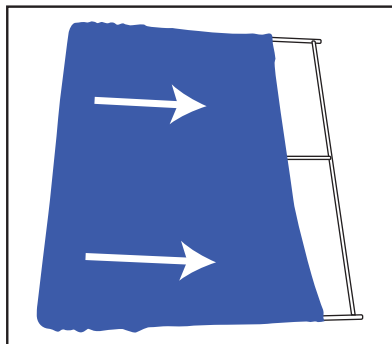

3. Pull pillowcase graphic over frame and zip bottom closed.

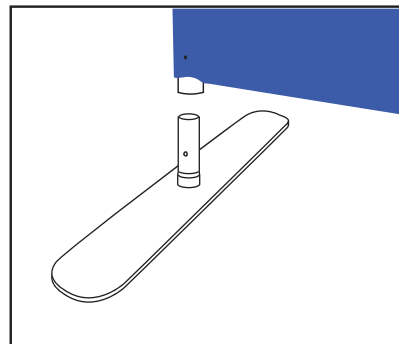

4. Attach the feet to the frame as seen in the diagram above.

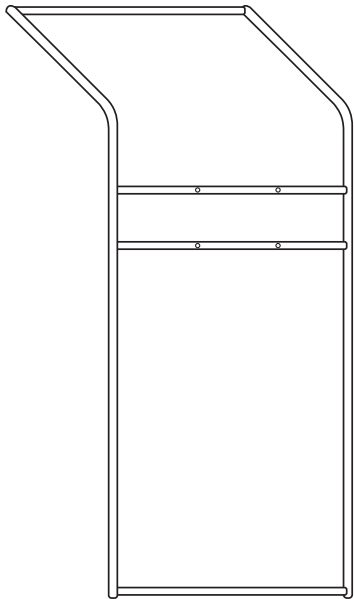
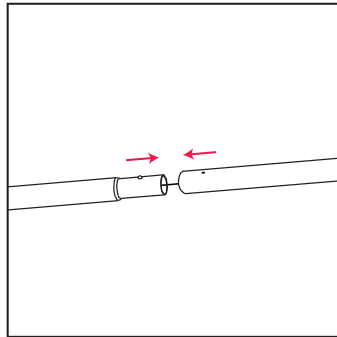
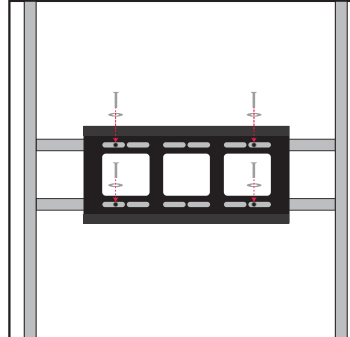

Diagram A



1. Matching the numbered stickers, assemble the frame as seen in Diagram A.



2. Attach monitor bracket plate on the horizontal support bars using four bolts, spacers, and washers.

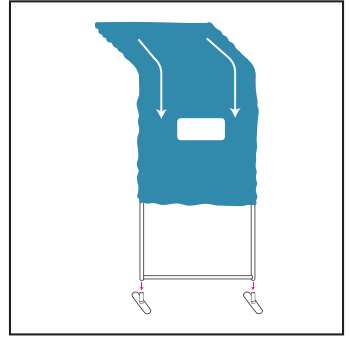

3. Pull the fabric graphic over the frame and zip up the bottom. Attach Feet to the bottom of the frame.

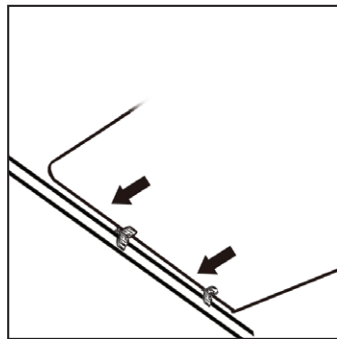

4. Attach arch frame to any 91" tall flat-top Ensemble frame using two clips.

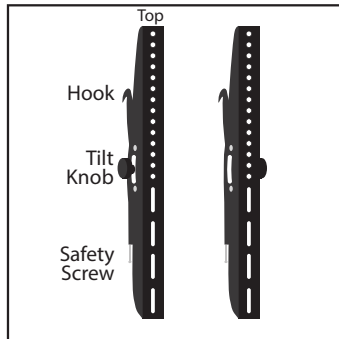

5. Attach the monitor bracket vertical bars to the back of the frame with the correct screw size for your monitor.



6. Hang the monitor in place via the vertical bar hooks and tighten the safety screws on the bottom.



Compatible with monitors up to 43" and 25 lbs.

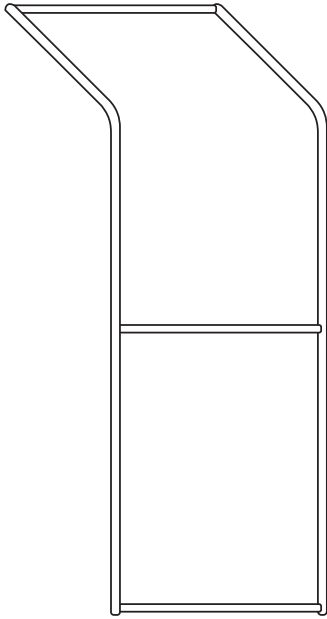
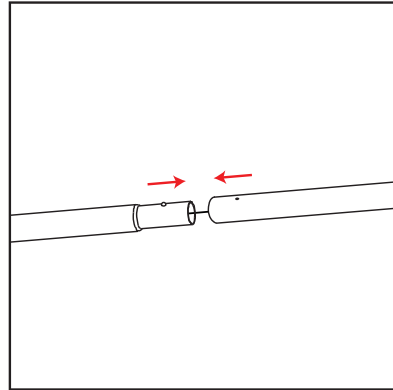
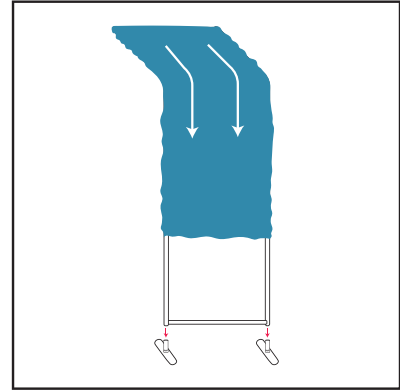

Diagram A



1. Matching the numbered stickers, assemble the frame as seen in Diagram A.



2. Pull the fabric graphic over the frame and zip up the bottom. Attach Feet to the bottom of the frame.

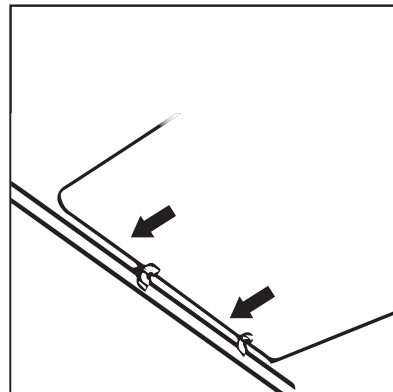

3. Attach arch frame to any 91" tall flat-top Ensemble frame using two clips.

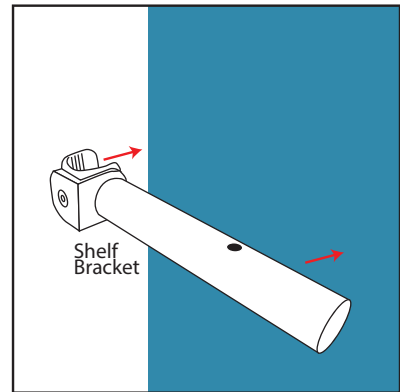

4. Clip the shelf brackets to the left and right sides of the frame.

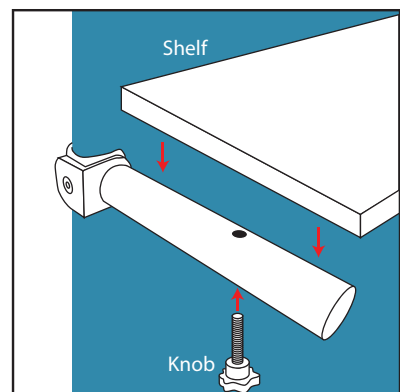
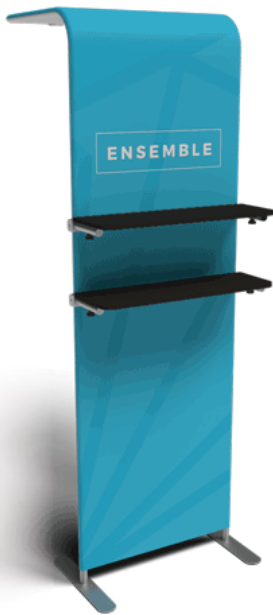

5. Set the shelf onto the brackets and make sure it's level. Attach the shelf with two knobs through the brackets.



Weight on shelves must not exceed 11 lbs per shelf.